



SECURITECH GROUP, INC.
GG • GS • LR SERIES TRIM
MARKING TEMPLATE

9000 Series Trim: ELECTROLATCH, MAGLATCH, GUARDIAN
 ARTE • ENDURALATCH • LEVEREX (LX)
 8000 Series GG Trim • 4900SL Series Trim (LL,LA/LD,LS)

DOOR & FRAME PREPARATION INFO:

Use the Lock Body or Exit Device template to locate the spindle hole (also known as the operator hole).

Electric Models ONLY

Wiring is to be brought from the frame to the lock area of the door. Review the specification to see if an electrified hinge or power transfer cord is to be used.

Please contact SECURITECH with any questions:

Phone: 718-392-9000
 Fax: 718-392-8944
 E-Mail: Help@securitech.com

TRIM DIMENSION

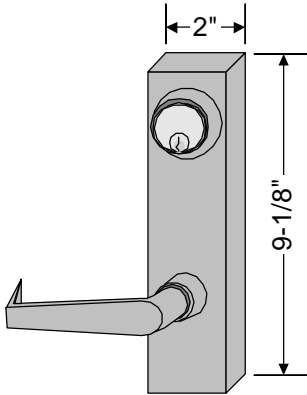

CENTER LINE OF DOOR - ADJUST FOR BEVEL

WIRING HOLE

- drill on exterior for all Electric Models
- drill thru door for Electric Models with ElectroMagnet

SPINDLE HOLE

- drill on exterior for 8000 Series push bar models / 4900 Exit Device models
- drill thru door for Mortise Lock Body models / Rim Exit Device models

see Mortise Lock Body or Exit Device template for Backset Distance

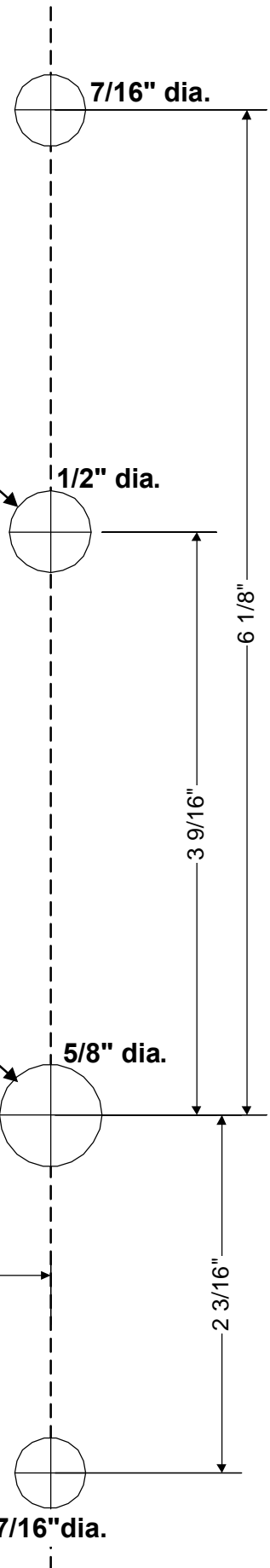

A Note About Templates:
 Any reproduction of this template, via fax, photocopy or digital transmission, renders it **Not To Scale.**